

STUDENT NAME \_\_\_\_\_

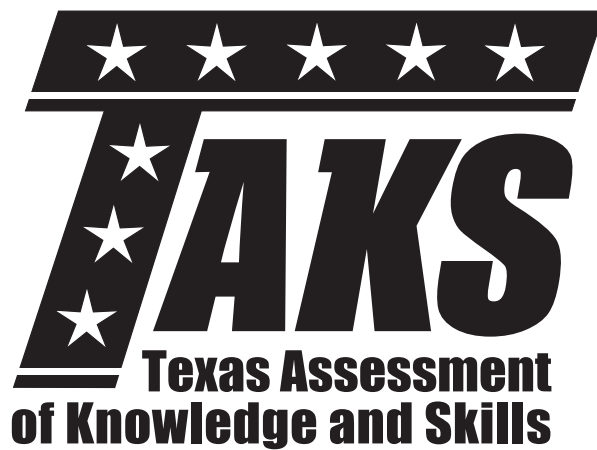

**GRADE 9  
READING  
MATHEMATICS**

**Administered Spring 2006**



# READING

## DIRECTIONS

Read the two selections and the viewing and representing piece. Then answer the questions that follow.

# A Horse for Matthew

*by William J. Buchanan*

- 1 My name is Tommy Silva. I am 14. I live in a large adobe house on the Jemez Indian Reservation in New Mexico, the ancient home of my people. For as long as I can remember, one room in that old house has been a world apart, an enchanted place of exciting smells and sights and things—my grandfather’s room. There, shelves on two walls are heavy with silver trophies, jeweled belts and medallions, awards recognizing Señor Martino Silva as the greatest rodeo champion ever to emerge from the Indian nations.
- 2 In this room my father was born, my grandmother died, and as a young boy I had often lain at night with my head cradled in Grandpa’s arm, listening to tales of an era that I could never know.
- 3 It was to this room one morning that I came to the past in hopes of shaping the future.
- 4 Grandpa was bent forward in his rocker, poking a pinion log burning in the fireplace. This was the first year he had kept a fire going during the summer. I settled into a nearby chair and stared silently into the amber flames.
- 5 Grandpa pulled his woolen coat tighter. “So, are you going to tell me what is troubling you?”
- 6 “It’s my friend, Grandpa. Matthew.”
- 7 “The Anglo boy the horse fell on?”
- 8 “They removed his cast last week. He was in it three months, Grandpa. He won’t even go near a horse now.”
- 9 Grandpa nodded. “I’ve seen this kind of fear in grown men, much less a 14-year-old boy.”
- 10 “It’s not right, Grandpa. I mean, down here in the valley, a kid not riding. He’ll be left out of everything.”
- 11 Grandpa rocked, saying nothing. I let the silence hang for a while, then said, “Grandpa, you know more about horses than anybody. Would you find a horse for Matthew?”
- 12 It took him by surprise. He leaned back in his chair and shook his head. “My eyes are tired. . . .” He noticed the hurt on my face and stopped. Then, with a deep sigh, he said, “Tell me about the boy.”

My notes about what I am reading

13 It poured from me in a torrent of words: Matthew's skill with horses before the accident, how we rode the mesa together, how he tended sick calves as if they were from his father's ranch instead of the Jemez Pueblo. At last Grandpa put a leathery hand on mine. "I will try, because it is you who ask."

14 THAT EVENING AFTER CHORES I rode across the Rio Jemez to the Cannon ranch. I tied Cheyenne to the hitching post and walked around to the back patio. Matthew was seated, resting his wounded leg atop a low wall. In the corral Mr. Cannon was working with two young colts. I pulled up a chair. "Your dad breaking yearlings?"

15 "Halter breaking," Matthew replied.

16 "Hey, man, let's go help."

17 "Oh, sure," he said. There was both fear and remorse in his voice.

18 We sat like that for a while. Leaden silence. Then, figuring it was now or never, I broke the news. "I've asked my grandpa to find you a horse."

19 "You what?"

20 I told him everything that was said that morning in Grandpa's room.

21 "I thought you were my friend," he snapped.

22 "I am your amigo. Look, the Pueblo trail ride is in six weeks. Unless you're riding, it won't—"

23 "Look, amigo"—he spit out the word with sarcasm—"I'm not going on any trail ride in six weeks, or six years, or anytime again. You get that?" He shoved his chair back and stood. "Do me a favor: Tend to your business and let me tend to mine." He stalked into the house and slammed the door.

24 It was as if I'd been slapped.

25 "What was that all about?" a familiar voice asked. I looked around and saw Matthew's dad. I told him what had taken place.

26 He thought for a moment. "Thanks, Tommy. If your granddad finds anything, call me."

- 27 EACH DAY FOR TWO WEEKS, Mama would drive Grandpa to a different ranch, and they would return with nothing to report. Then, one evening, Grandpa said, "Have the boy and his father meet me tomorrow at Broadbents."
- 28 "Broadbents?" I said, puzzled. "Grandpa, that's a slaughterhouse."
- 29 "Just be there." He sipped his coffee without another word.
- 30 Broadbents Stockyard was west of Albuquerque on old Route 66. Grandpa and I were talking to the owner when Mr. Cannon arrived. Matthew had refused to come.
- 31 Grandpa pointed to a pinto standing alone. She was small. Her glossy summer coat shone like a burnished checkerboard. "There is the horse for Matthew," Grandpa said.
- 32 MR. CANNON STEPPED around for a closer look. The owner eyed him carefully, then said, "Mister, you don't want that mare."
- 33 Mr. Cannon turned. "Oh? Why?"
- 34 "Those are slaughter horses. Something wrong with all of them. Someone's mistreated that little paint. You can't get close to her."
- 35 "I don't understand," Mr. Cannon said. "Señor Silva, are you sure this is the horse for me?"
- 36 Grandpa shook his head. "Not for you," he said firmly. "For the boy."
- 37 Their eyes met for a moment, then Mr. Cannon turned to the owner. "How much for the mare?"
- 38 The owner shrugged. "She was going for four cents a pound for dog meat. Forty dollars and she's yours."
- 39 It took some doing, but we got her back to Cannon's ranch and led her into the small corral. We set out to gain her confidence, but nothing tempted her. Open the gate and she'd bolt madly to the far end of the lot. The mere sight of a rope caused her to panic.
- 40 At first, Matthew watched from the safety of the patio. Then one day he started coming to the corral. Favoring his wounded leg, he'd pull himself atop the fence. One day he yelled, "She jumps around like a Pueblo sun dancer."

42 IN THE BEGINNING, Matthew would leave the corral when we did. Then he started lingering behind, closely studying Sundance. And she studied him. Sensing that he was as apprehensive of her as she was of him, she began to accept his presence. One day he picked a handful of clover and held it over the fence. She cocked her head, hesitated a moment, then quickly nibbled it from his hand. In a few days she was coming to the fence to meet him. But the fence was always there, always between them.

43 Then came the day Mr. Cannon asked me to help trim Sundance’s hooves. Before we could corner her, she spotted the lariats. Emitting a sharp cry, she lowered her head and dashed toward the barbed-wire fence. Flexing her powerful muscles she tried to clear the barrier. Her rear fetlocks caught. She crashed to the ground, savagely entangled in the sharp wire. In a few minutes she would cut herself to ribbons.

44 “Hold her still! I’ll get the wire cutters!” Mr. Cannon yelled.

45 Suddenly, he was there, limping toward the terrified mare. “Matthew! Stop!” I cried.

46 Dodging flailing hooves, he put a hand on her face, softly, gently speaking to her. For an agonizing moment, she froze. Then, slowly, she exhaled a shuddering moan and lay back, quiet.

47 “The rope,” Matthew said.

48 I put the lariat in his hand. He eased the noose over Sundance’s head and held her while his dad snipped the wire from her legs. Matthew coaxed her and she stood.

49 WHILE MR. CANNON AND I watched from the porch, Matthew washed and treated Sundance’s wounds. All that day, and in the days that followed, he tended her while she healed.

50 But he still wouldn’t ride, still wouldn’t approach other horses. I decided my efforts were in vain.

51 One morning before dawn, three weeks later, the annual Pueblo trail ride set out from Pueblo Plaza. We were crossing the Rio Jemez heading for Red Rock Canyon when I heard the cry: “Hey, amigo, wait up!”

52 They came at full gallop, Matthew astride Sundance, wounded boy and wounded horse. I reined up and tried to speak. All that would come was a reverent whisper: “Madre de Dios . . . Madre de Dios (Mother of God).” Tears stung my cheeks. I wondered if Matthew could see them.

53 WE RODE SIDE-BY-SIDE, lagging behind the others. I said, “You’ve been working with her in secret, haven’t you?”

54 “Yeah,” he admitted. He patted Sundance. “She wouldn’t have much to do with you or Dad, would she?”

55 “No,” I chuckled, “she sure wouldn’t.”

56 “She took to me right off, though. Guess I’m the only one who really understood her.”

57 “No, amigo, not the only one,” I replied. And I thought of a soft-spoken old man in his rocking chair staring into a pinion fire. Grandpa had understood the little horse—and more besides.

Used by permission of William J. Buchanan.



# Hello, Old Paint

by Jeanne Marie Laskas

1 The check bounced. “Insufficient funds,” says the little note attached. Well, I’m sure it’s just a mistake. Probably the people didn’t make a transfer in time or something. “No big deal,” I keep saying to myself, standing at the mailbox.

2 But the check bounced! Isn’t that strange? I mean, is there a message here? The check was payment to us for the sale of Cricket, our ex-horse, and Sassy, our ex-mule. A sale, truth be told, I’ve been regretting. And now the check has bounced. Is it a sign?

3 No, of course not. Probably just a clerical error.

4 Even so, as I take the long walk back home, I get a picture in my head. I imagine that somehow Cricket and Sassy understand that the check bounced, that they understand the legal ramifications of this, that technically the deal is null and void, and in one burst of horse energy they leap over the buyer’s fence and come bounding in slow motion, as if in a shampoo commercial, up our driveway, toward me, kicking and snorting with glee, and I run toward them and we hug and live happily ever after. Together. As it was meant to be.

5 When I get home I snap out of it. No, we did the right thing, selling Cricket and Sassy. They’re in a better place now. Cricket will be a brood mare. A mom!

6 And Sassy, her friend, will be at her side. It’s better for them. Better for us. Cricket, a registered American saddlebred, is too much horse for novices like us. And

Sassy is too short for an adult to ride. And we have another horse and mule that we do ride. So this really is the best thing for all concerned. And what did I tell myself? Yes, some friendships are meant to end. That’s it. Never mind that Cricket was our love-horse, the horse that walked up our driveway on our wedding day. And Sassy was our love-mule, the mule that walked up our driveway beside her. They had flowers in their hair. Never mind! Because some friendships are just meant to end. And I am a mature person with a logical head who understands this.

So I call Cricket and Sassy’s new owners. “The check bounced,” I say.

“Oh, that’s our stupid bank,” the woman says. Then she gives me her bank’s stupid phone number, should I want to call for proof that her account is in good standing, which I don’t really, but I write the number down anyway. “Just resubmit the check, okay?” she says. I ask her how Cricket and Sassy are doing, and she says, “Great!” Nothing more. I wish she had said more.

Meantime, all this horse thinking gets my mind on Billy. Because not all fading friendships are meant to end. Billy is the neighbor who sold Cricket and Sassy to us. He’s the one who rode Sassy up the driveway on our wedding day, his feet dragging on the ground. Tom, his son, rode Cricket. They’re the ones who put the

■ see Old Paint, page 2

flowers in their hair. Billy and I used to see each other more. I don't know why we've drifted. There never seems to be a real reason for friendships to fade. Friendships take work. Maybe that's all there is to it.

10 I call Billy just to say hi. He seems happy to hear from me. "We got a donkey!" he says. "She's so goofy. You'd love her." I tell him the news about Cricket and Sassy, and when I mention the buyers he seems concerned: "Did you happen to insist on a certified check?"

11 Oh.

12 Sure enough, a few days later, I'm at the mailbox. "Insufficient funds." I can't believe it. What do they think, I'm an idiot or something? I stomp into the house. What about that bank phone number? I'll call that bank, I'll get to the bottom of this. What did I do with that number? I must have thrown it out. I start picking through the trash.

13 Here it is! But the paper is wet and the number is blurred.

14 Isn't that strange? I mean, is there a message here? It's hard not to think of disappearing ink as a message from above. I start getting shampoo commercials in my head again. Oh, dear.

15 Why am I putting myself through all of this? Why can't I just admit that I made a mistake? Not just the part about selling my beloved pets to, well, some questionable buyers. But selling them at all. And, anyway, why can't we breed Cricket? A lot of work, perhaps. But wouldn't that be an amazing experience?

16 I imagine Cricket back in our barn. I imagine brushing her, telling her everything I've learned. "Well, Cricket, friendships take work," I'll say. "That's all there is to it."

17 So I call the woman, sound very businesslike. "The check bounced again," I say calmly. "The deal is off." Strangely, she doesn't sound surprised. I get the distinct sense she and her husband have been through this before.

18 I call Billy. "Would you be able to go pick up Cricket and Sassy in your horse trailer and bring them back home?" I ask. He says of course. No questions asked. And I think that's what friends are for. And I say yeah, I'd love to stop over and meet his new donkey.

Originally published in The Washington Post magazine by Jeanne Marie Laskas.

# Friends for Life

the magazine for friends

August  
\$1.75

**What Kind of  
Friend Are You?**  
Take Our Quiz

**Find Your New  
Best Friend . . .**  
at the Animal Shelter!

**Making Friendship  
Bracelets**  
A Step-by-Step Guide

**Are You Fighting  
with a Friend?**  
10 Foolproof Ways to  
Say "I'm Sorry"

Photograph courtesy of © Royalty Free/CORBIS.

Use “A Horse for Matthew” (pp. 4–8) to answer questions 1–16.

- 1 In paragraph 43, the word *emitting* means —
- A uttering
  - B viewing
  - C rushing
  - D whispering
- 2 Tommy’s grandfather was once well known as a —
- F horse trainer
  - G belt maker
  - H rodeo champion
  - J horse breeder
- 3 Approximately how long does it take Grandpa to find the right horse for Matthew?
- A A month
  - B A couple of days
  - C All summer
  - D Two weeks
- 4 How was Matthew’s leg broken?
- F A horse threw him.
  - G He had a rodeo accident.
  - H A horse fell on him.
  - J The corral fence collapsed.
- 5 Paragraph 42 is mainly about —
- A Matthew and Sundance becoming acquainted
  - B what horses like to eat while in the corral
  - C fences and their usefulness on ranches
  - D Matthew leaving the corral with the others
- 6 The primary conflict in the story is between —
- F Tommy and Grandpa
  - G Matthew and his fear
  - H Matthew and Sundance
  - J Tommy and his anger
- 7 Which line from the story best reveals Grandpa’s love for Tommy?
- A “*Tell me about the boy.*”
  - B “*So, are you going to tell me what is troubling you?*”
  - C “*I’ve seen this kind of fear in grown men. . . .*”
  - D “*I will try, because it is you who ask.*”
- 8 In paragraph 18, the author uses the phrase “leaden silence” to create a mood of —
- F suspicion
  - G mystery
  - H anger
  - J discomfort

- 9 Paragraph 12 tells the reader that Grandpa —
- A knows nothing about Matthew
  - B does not want to disappoint Tommy
  - C usually spends the day in his chair
  - D is not accustomed to being surprised
- 10 Which of the following foreshadows Tommy's intention to ask his grandfather for help?
- F *I settled into a nearby chair and stared silently into the amber flames.*
  - G *"They removed his cast last week. He was in it three months, Grandpa."*
  - H *Grandpa was bent forward in his rocker, poking a pinion log burning in the fireplace.*
  - J *It was to this room one morning that I came to the past in hopes of shaping the future.*
- 11 The story's point of view helps the reader understand —
- A the difficulty of working with wild horses
  - B the fear that Matthew experiences
  - C the depth of Tommy's concern for Matthew
  - D the importance of horses on the reservation
- 12 Paragraph 23 shows the reader that Matthew is feeling —
- F disappointed by Tommy's visit
  - G nervous about having to stay at home
  - H indifferent about being injured
  - J frustrated with his current situation
- 13 Tommy knows that Matthew's conflict has been resolved when —
- A Tommy visits Matthew
  - B Sundance gets hurt
  - C Matthew rides Sundance
  - D Grandpa finds the horse
- 14 Paragraph 8 suggests that —
- F Matthew will soon ride again
  - G Tommy is ashamed of Matthew's fear
  - H Matthew's accident was very serious
  - J Tommy is also afraid of horses
- 15 Based on Matthew's behavior around Sundance, the reader can conclude that Matthew —
- A has never trained a horse before
  - B plans to ride the horse on the trail ride
  - C does not like horses
  - D understands the horse's fear
- 16 The reader can infer from paragraph 24 that —
- F Matthew is not a good friend
  - G Matthew has hurt Tommy's feelings
  - H Matthew cannot forgive Tommy
  - J Matthew is jealous of Tommy

Use “Hello, Old Paint” (pp. 9–10) to answer questions 17–28.

17 When the author finally found the paper with the bank’s phone number on it, it was difficult to read because —

- A the paper was wet
- B the handwriting was poor
- C the author could not see well
- D the seller had made a mistake

18 Read the following dictionary entry.

**bounce** \ˈbaʊn(t)s\ *v* **1.** to cause to rebound after striking a surface **2.** to dismiss from employment; fire **3.** to present an idea to another person for comments or approval **4.** to be returned by a bank because of a shortage of money

Which definition best matches the use of the word *bounced* in paragraph 1?

- F Definition 1
- G Definition 2
- H Definition 3
- J Definition 4

19 Paragraphs 5 and 6 are mainly about —

- A how much trouble the animals had become
- B how the author rationalized the sale of her pets
- C how angry the author was with the buyers of Cricket and Sassy
- D why American saddlebreds are lovable horses

20 The author had good memories of Cricket and Sassy because —

- F they were gifts from the author’s husband
- G the author and her husband rode Cricket and Sassy frequently
- H Cricket and Sassy participated in the author’s wedding
- J the author had raised the animals from birth

21 What caused the author’s primary conflict?

- A She couldn’t ride Sassy.
- B She didn’t have enough money.
- C She missed her friend Billy.
- D She regretted selling her pets.

22 In paragraph 12, the author was —

- F nervous
- G tired
- H frustrated
- J timid

- 23** Which lines show that the author was beginning to question her decision to sell Cricket and Sassy?
- A** *I ask her how Cricket and Sassy are doing, and she says, "Great!" Nothing more.*
  - B** *What do they think, I'm an idiot or something? I stomp into the house.*
  - C** *"Well, Cricket, friendships take work," I'll say. "That's all there is to it."*
  - D** *But the check bounced! Isn't that strange? I mean, is there a message here?*
- 24** What sort of tone does the author create in this selection?
- F** Reflective
  - G** Comical
  - H** Mysterious
  - J** Unemotional
- 25** The reader can conclude that the people who bought Cricket and Sassy —
- A** were new to the neighborhood
  - B** did not manage money well
  - C** had other horses of their own
  - D** were not kind to their horses
- 26** In paragraph 8, the sentence "I wish she had said more" shows —
- F** how much the author missed Cricket and Sassy
  - G** the rudeness of the buyer toward the author
  - H** that the author feared the animals might have been ill
  - J** that the buyer was too busy to talk with the author
- 27** How did the author persuade herself that she had made the right decision to sell her animals?
- A** She recognized that the money from the sale would help her family.
  - B** She told herself that the animals were better off with the new owners.
  - C** She accepted Billy's opinion that she had made a wise choice.
  - D** She admitted that the buyers were responsible businesspeople.
- 28** Based on paragraph 18, the reader can conclude that —
- F** friends are not very important to the author
  - G** the author will resume her friendship with Billy
  - H** animals are more important to the author than people
  - J** the author will give Cricket and Sassy to Billy

**Use “A Horse for Matthew” and “Hello, Old Paint” (pp. 4–10)  
to answer questions 29 and 30.**

**29** Which theme do both selections address?

- A** Family members can be wise and supportive.
- B** Never conduct business with friends.
- C** Fear is a damaging emotion.
- D** Friendships are worth preserving.

**30** The reader can conclude that the authors of “A Horse for Matthew” and “Hello, Old Paint” —

- F** write only about events that have actually happened
- G** see similarities between horses and people
- H** understand the business of breeding horses
- J** have written extensively about animals



**Use the visual representation on page 11 to answer questions 31–33.**

**31** The magazine’s publishers probably intend for the cover photograph to illustrate —

- A** the importance of telephone communication
- B** the difficulty of apologizing to friends
- C** the positive aspects of friendship
- D** the challenges of finding time to spend together

**32** The publishers of this magazine want readers to believe that it can —

- F** strengthen reading skills
- G** increase volunteerism
- H** prevent arguments
- J** improve friendships

**33** Which of the following articles would best fit the primary purpose of the magazine?

- A** “Why I Can’t Talk to My Mom”
- B** “Sisters—The Real Best Friends”
- C** “Friendly Relations Between Governments”
- D** “How to Break Up with Your Boyfriend”

## DIRECTIONS

Answer the following questions in the space provided on the answer document.

- 34 In “A Horse for Matthew,” what do Matthew and Sundance have in common? Explain your answer and support it with evidence from the selection.
- 35 What did the author of “Hello, Old Paint” learn from her experience? Explain your answer and support it with evidence from the selection.
- 36 How is the bond between humans and animals important in both “A Horse for Matthew” and “Hello, Old Paint”? Support your answer with evidence from **both** selections.

BE SURE YOU HAVE WRITTEN YOUR ANSWERS  
ON THE ANSWER DOCUMENT.





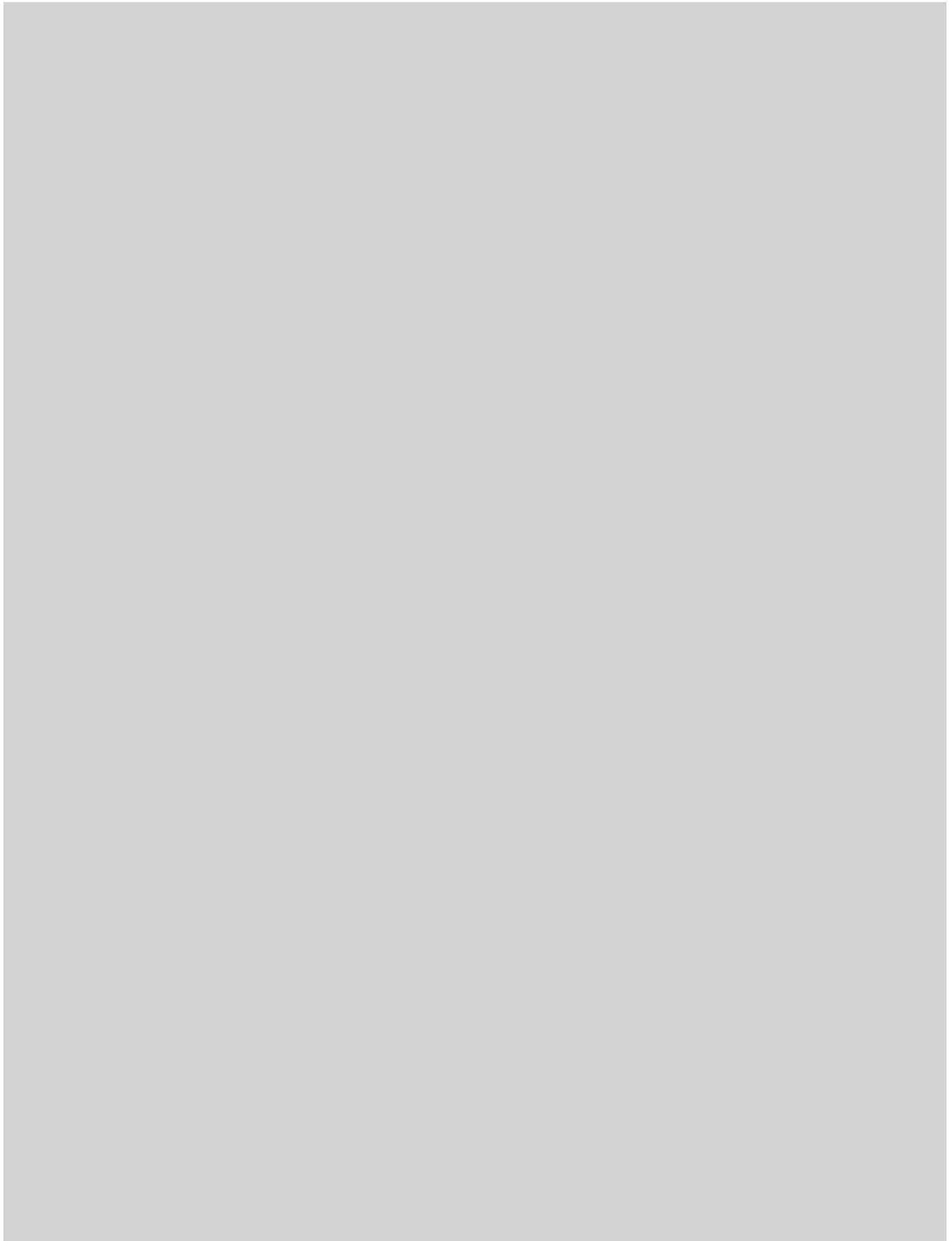

# MATHEMATICS



# Mathematics Chart

## LENGTH

### Metric

1 kilometer = 1000 meters

1 meter = 100 centimeters

1 centimeter = 10 millimeters

### Customary

1 mile = 1760 yards

1 mile = 5280 feet

1 yard = 3 feet

1 foot = 12 inches

## CAPACITY AND VOLUME

### Metric

1 liter = 1000 milliliters

### Customary

1 gallon = 4 quarts

1 gallon = 128 ounces

1 quart = 2 pints

1 pint = 2 cups

1 cup = 8 ounces

## MASS AND WEIGHT

### Metric

1 kilogram = 1000 grams

1 gram = 1000 milligrams

### Customary

1 ton = 2000 pounds

1 pound = 16 ounces

## TIME

1 year = 365 days

1 year = 12 months

1 year = 52 weeks

1 week = 7 days

1 day = 24 hours

1 hour = 60 minutes

1 minute = 60 seconds

Metric and customary rulers can be found on the separate Mathematics Chart.

# Mathematics Chart

<b>Perimeter</b>	rectangle	$P = 2l + 2w$ or $P = 2(l + w)$
<b>Circumference</b>	circle	$C = 2\pi r$ or $C = \pi d$
<b>Area</b>	rectangle	$A = lw$ or $A = bh$
	triangle	$A = \frac{1}{2}bh$ or $A = \frac{bh}{2}$
	trapezoid	$A = \frac{1}{2}(b_1 + b_2)h$ or $A = \frac{(b_1 + b_2)h}{2}$
	circle	$A = \pi r^2$
<b>Surface Area</b>	cube	$S = 6s^2$
	cylinder (lateral)	$S = 2\pi rh$
	cylinder (total)	$S = 2\pi rh + 2\pi r^2$ or $S = 2\pi r(h + r)$
	cone (lateral)	$S = \pi rl$
	cone (total)	$S = \pi rl + \pi r^2$ or $S = \pi r(l + r)$
	sphere	$S = 4\pi r^2$
<b>Volume</b>	prism or cylinder	$V = Bh^*$
	pyramid or cone	$V = \frac{1}{3}Bh^*$
	sphere	$V = \frac{4}{3}\pi r^3$
<i>*B represents the area of the Base of a solid figure.</i>		
<b>Pi</b>	$\pi$	$\pi \approx 3.14$ or $\pi \approx \frac{22}{7}$
<b>Pythagorean Theorem</b>		$a^2 + b^2 = c^2$
<b>Distance Formula</b>		$d = \sqrt{(x_2 - x_1)^2 + (y_2 - y_1)^2}$
<b>Slope of a Line</b>		$m = \frac{y_2 - y_1}{x_2 - x_1}$
<b>Midpoint Formula</b>		$M = \left( \frac{x_1 + x_2}{2}, \frac{y_1 + y_2}{2} \right)$
<b>Quadratic Formula</b>		$x = \frac{-b \pm \sqrt{b^2 - 4ac}}{2a}$
<b>Slope-Intercept Form of an Equation</b>		$y = mx + b$
<b>Point-Slope Form of an Equation</b>		$y - y_1 = m(x - x_1)$
<b>Standard Form of an Equation</b>		$Ax + By = C$
<b>Simple Interest Formula</b>		$I = prt$



## DIRECTIONS

Read each question. Then fill in the correct answer on your answer document. If a correct answer is not here, mark the letter for “Not here.”

### SAMPLE A

Find the slope of the line  $2y = 8x - 3$ .

A  $-\frac{3}{2}$

B 4

C 8

D Not here

### SAMPLE B

Janice uses a rectangular box to store her art supplies. The dimensions of the rectangular box are 22.5 inches by 14 inches by 11.5 inches. What is the volume of this box in cubic inches?

Record your answer and fill in the bubbles on your answer document. Be sure to use the correct place value.



1 The graph of a function is shown below.

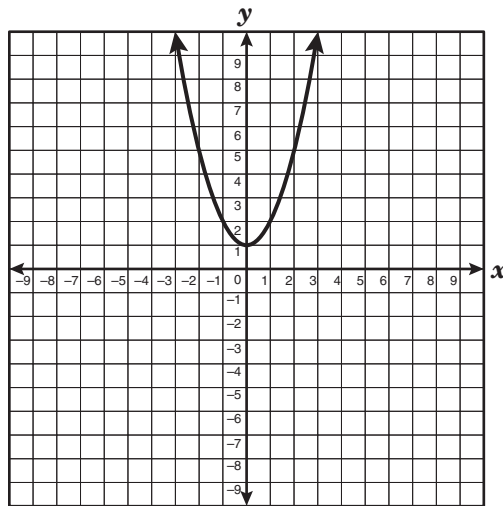

If the graph is translated 7 units down, which of the following best represents the resulting graph?

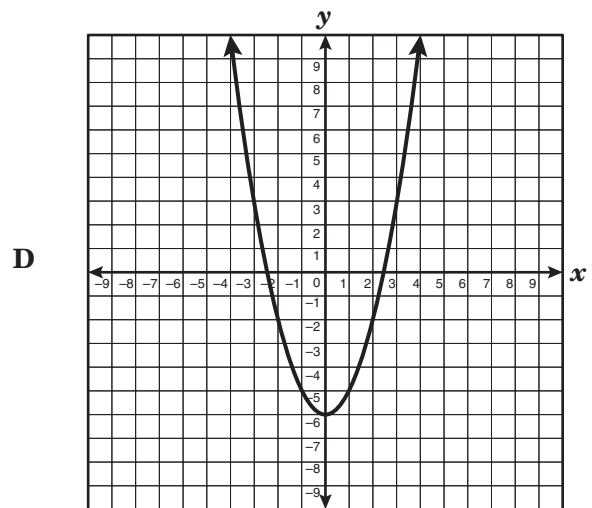
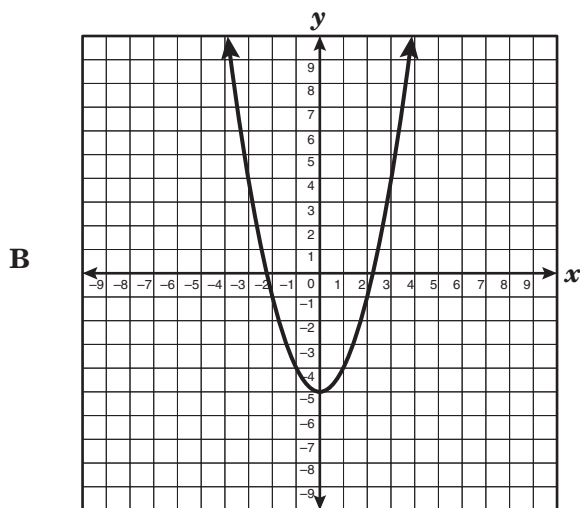
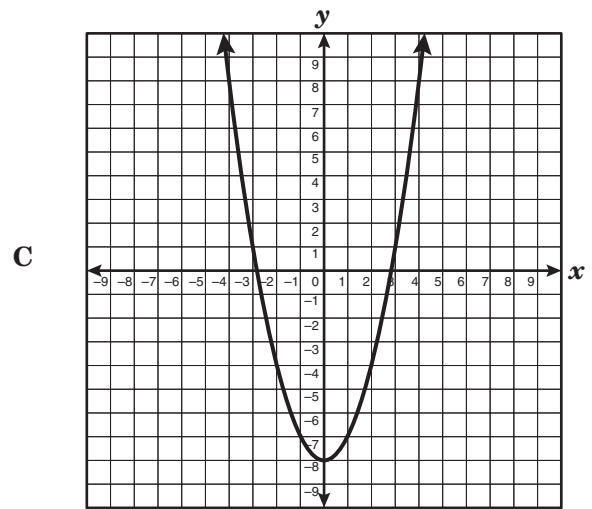
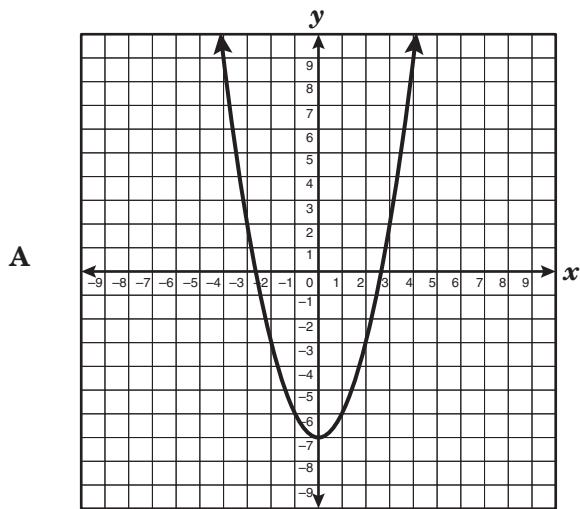

- 2 Points  $K$  and  $L$  are shown on the grid below.

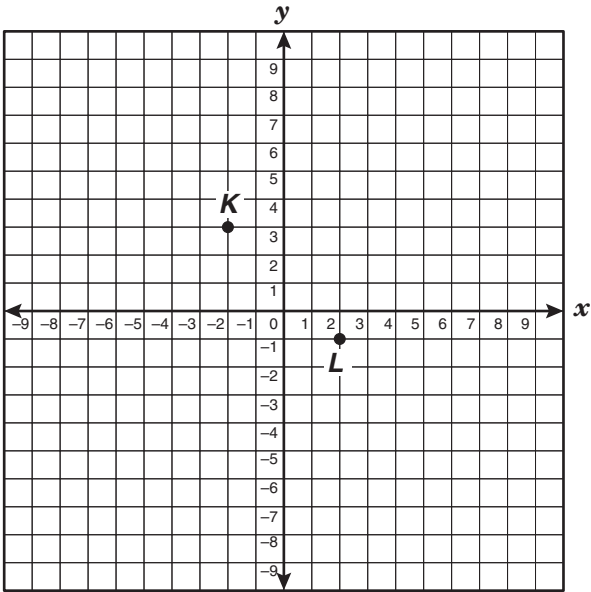

If point  $K$  is the midpoint of  $\overline{JL}$ , what are the coordinates of endpoint  $J$ ?

- F  $(6, -5)$
- G  $(-6, 7)$
- H  $(0, 1)$
- J  $(-4, 5)$

- 3 If  $a < b$  and  $b = c$ , which statement must be true?

- A The values of  $a$ ,  $b$ , and  $c$  are positive.
- B The values of  $a$ ,  $b$ , and  $c$  are negative.
- C The value of  $a$  is less than the value of  $c$ .
- D The value of  $a$  is greater than the value of  $c$ .

- 4 The drawing below shows both the top view of a solid structure built with identical cubes as well as the number of cubes in each column of the structure.

2	3	3
3	2	3
2	1	1
1	2	1

Front

Which 3-dimensional view best represents the same structure?

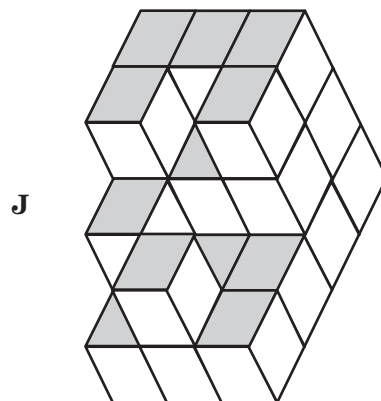
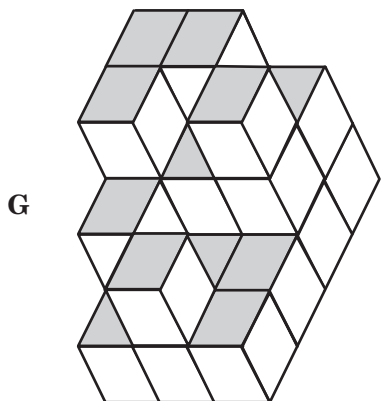
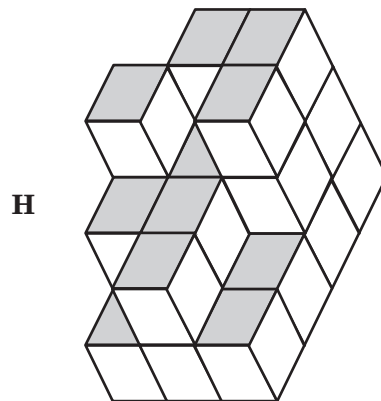
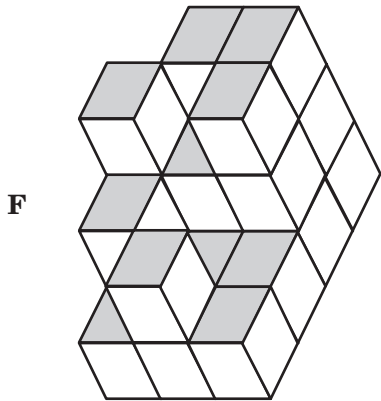

5 Which inequality best describes the graph shown below?

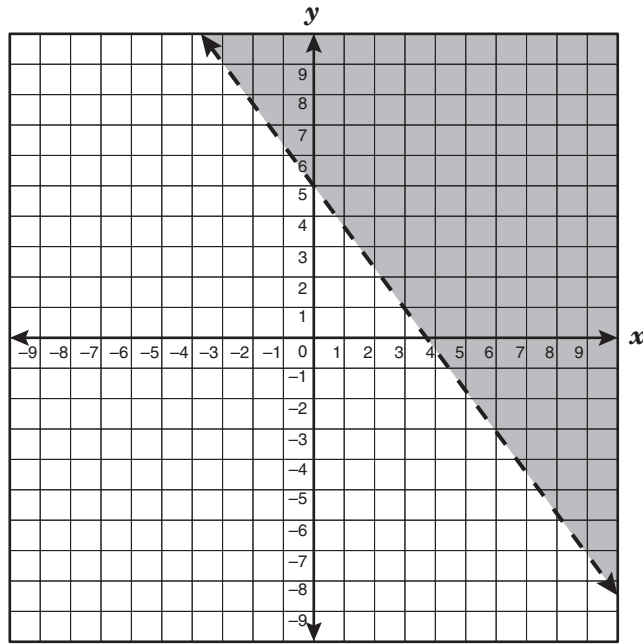

A  $y > -\frac{3}{4}x + 5$

B  $y < -\frac{4}{3}x + 5$

C  $y < -\frac{3}{4}x + 5$

D  $y > -\frac{4}{3}x + 5$

6 Ronald wants to buy a shirt that is on sale for 15% off the regular price. The regular price of the shirt is  $p$  dollars. Which expression represents the sale price of the shirt?

F  $p - 0.15p$

G  $p + 0.15p$

H  $p - 15p$

J  $0.15p$

- 7 The horizontal distance and the vertical distance between the pegs on the geoboard shown below each represent 1 unit.

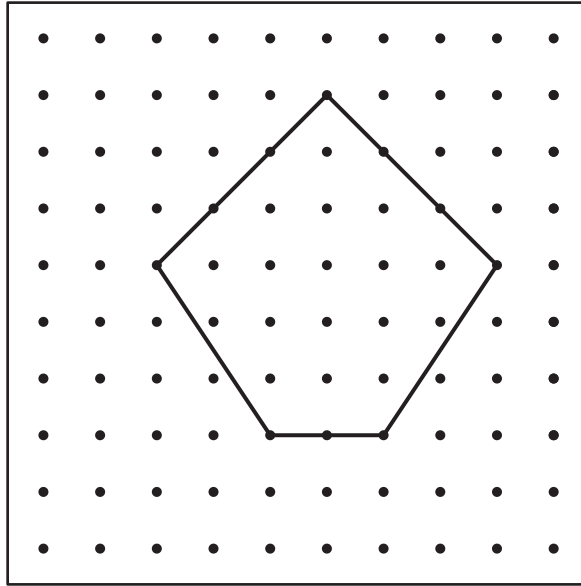

Which is closest to the area of the polygon modeled on the geoboard?

- A 34 units<sup>2</sup>
- B 27 units<sup>2</sup>
- C 21 units<sup>2</sup>
- D 17 units<sup>2</sup>

8 Olga plans to take a trip from her house in San Marcos, Texas, to a friend's house in Zapata, Texas. She measured the distance between the two places on a map and found it to be 8 inches. If the scale on the map is  $\frac{1}{2}$  inch represents 14 miles, which is closest to the actual distance in miles between the two places?

F 112 mi

G 224 mi

H 56 mi

J 44 mi

- 9 The net of a cube is shown below. Use the ruler on the Mathematics Chart to measure the dimensions of the cube to the nearest tenth of a centimeter.

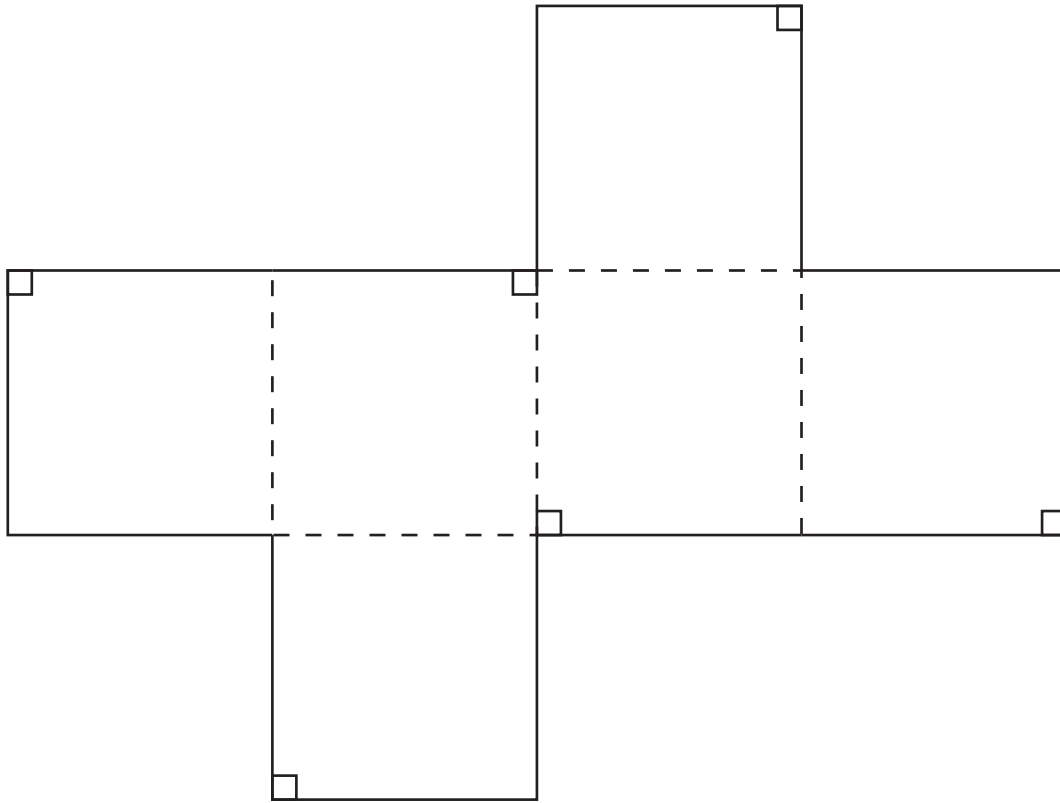

Which is closest to the total surface area of the cube represented by this net?

- A  $74 \text{ cm}^2$   
B  $11 \text{ cm}^2$   
C  $43 \text{ cm}^2$   
D  $12 \text{ cm}^2$
- 
- 10 If  $(x, -3.2)$  is a solution to the equation  $4x = 5y - 17$ , what is the value of  $x$ ?
- F 0.84  
G 0.25  
H  $-5.96$   
J  $-8.25$



- 11 A small business purchased a van to handle its delivery orders. The graph below shows the value of this van over a period of time.

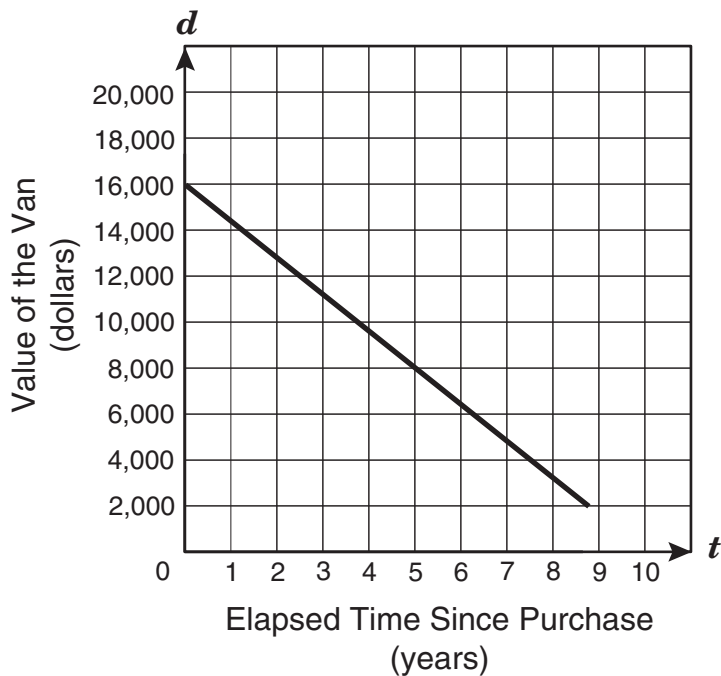

Which of the following best describes this situation?

- A The van was purchased for \$1,600.
- B The van decreases in value by \$1,600 per year.
- C The van increases in value by \$1,600 per year.
- D The van has no value after 5 years.

- 12 The graph of a linear function is shown on the coordinate grid below.

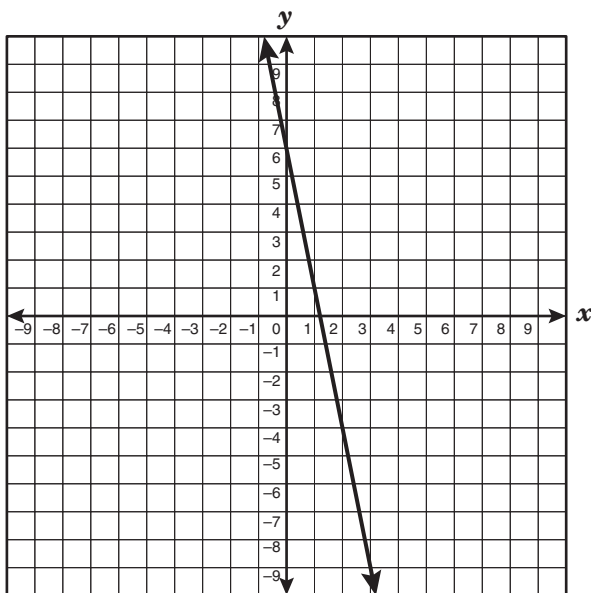

If the  $y$ -intercept is changed to  $(0, 5)$  and the slope becomes  $-4$ , which statement best describes the relationship between the two lines when they are graphed on the same coordinate grid?

- F The  $y$ -intercepts are 1 unit apart, and the lines are parallel.
- G The  $y$ -intercepts are 1 unit apart, and the lines intersect at  $(1, 1)$ .
- H The  $y$ -intercepts are 1 unit apart, and the lines are perpendicular.
- J The  $y$ -intercepts are 1 unit apart, and the lines intersect at  $(1, 0)$ .

- 13 The astronomy club rented a bus to visit the planetarium. The club rented the bus at a rate of \$24.95 per day plus \$0.45 per mile driven over 50 miles. If the astronomy club rented the bus for 1 day, what additional information is needed to determine the total cost of renting the bus?

- A The total number of students in the astronomy club
- B The number of hours the bus was driven each day
- C The number of days the bus was rented
- D The total number of miles the bus was driven

- 14 Mrs. Lee bought a small rectangular box that contains 10 tightly packaged erasers shaped like rectangular prisms, as shown below.

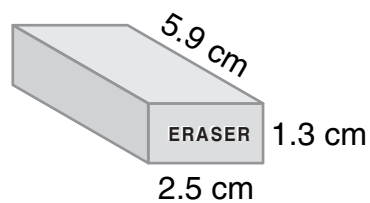
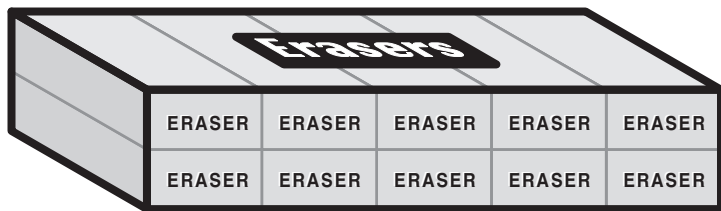

What is the approximate volume in cubic centimeters of this rectangular box?

- F  $19 \text{ cm}^3$   
G  $97 \text{ cm}^3$   
H  $192 \text{ cm}^3$   
J  $513 \text{ cm}^3$
- 
- 15 The table below shows various values for  $x$  and  $y$ .

$x$	$y$
-6	23
-2	11
7	-16
11	-28

Which equation best describes the relationship between  $x$  and  $y$ ?

- A  $y = -3x + 5$   
B  $y = -5x - 7$   
C  $y = -x + 17$   
D  $y = 3x + 41$

- 16 Tammy drew a floor plan for her kitchen, as shown below.

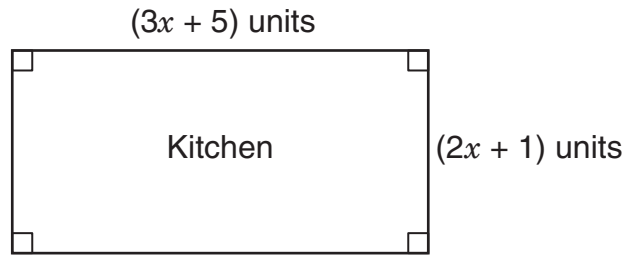

Which expression represents the area of Tammy's kitchen floor in square units?

- F  $6x^2 + 30x + 5$
- G  $6x^2 + 13x + 5$
- H  $10x + 12$
- J  $5x + 6$

- 17 What is the slope of the line that contains the coordinate points  $(8, -3)$  and  $(-2, 7)$ ?

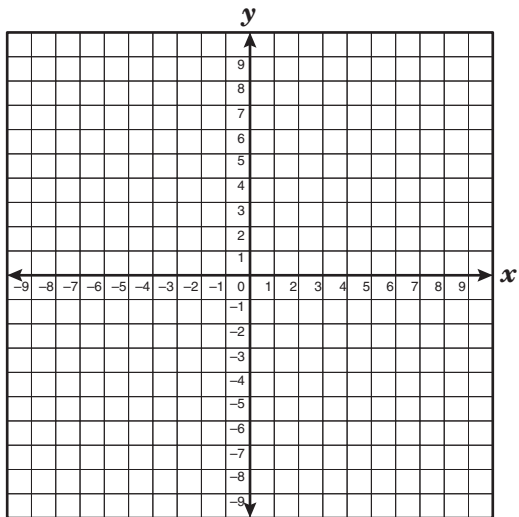

- A  $-1$
- B  $-\frac{9}{11}$
- C  $-\frac{5}{3}$
- D  $-\frac{2}{5}$

- 18 Mr. Rivera wants to build a barbed-wire fence containing 5 rows of barbed wire around the irregularly shaped area shown in the drawing below.

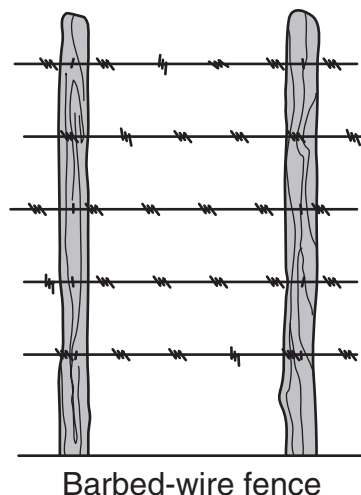
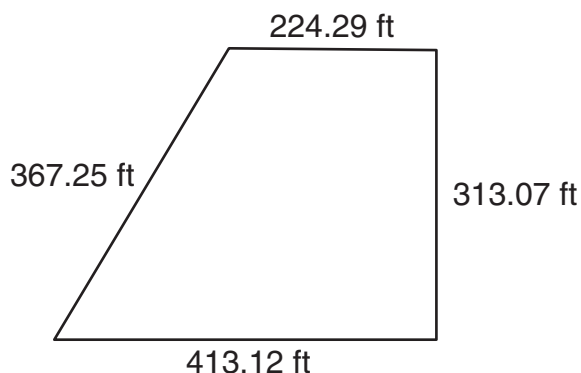

Mr. Rivera wants to purchase rolls of barbed wire that contain 1380 linear feet of wire per roll and purchase an extra 500 linear feet of wire for a gate for the fence. Which of the following is a correct method for Mr. Rivera to calculate the total number of rolls of barbed wire he will need to purchase?

- F Determine the area of the property, multiply by 5, and then divide by the sum of 1380 and 500
- G Determine the perimeter of the property, multiply by 5, add 500, and then divide by 1380
- H Determine the area of the property, multiply by 5, add 500, and then divide by 1380
- J Determine the perimeter of the property, multiply by 5, and then divide by the sum of 1380 and 500

- 19 Which of the following ordered pairs is the  $x$ -intercept or the  $y$ -intercept of the function  $2x - y = 8$ ?

- A (8, 0)
- B (0, 4)
- C (4, 0)
- D (0, 8)

20  $\triangle AHP \sim \triangle ENK$  as shown below.

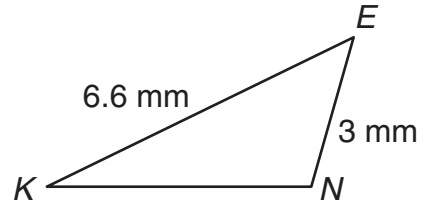
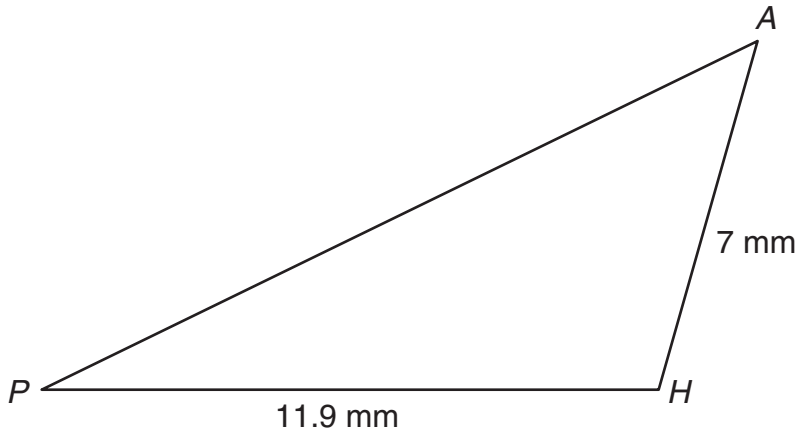

Which scale factor was used to transform  $\triangle AHP$  to  $\triangle ENK$ ?

F  $\frac{10}{17}$

G  $\frac{3}{7}$

H  $\frac{11}{20}$

J  $\frac{1}{4}$

21 If a wheel spins at a rate of 36 revolutions per minute, how many revolutions per hour does the wheel spin?

Record your answer and fill in the bubbles on your answer document. Be sure to use the correct place value.

22 Which graph below best represents the linear parent function?

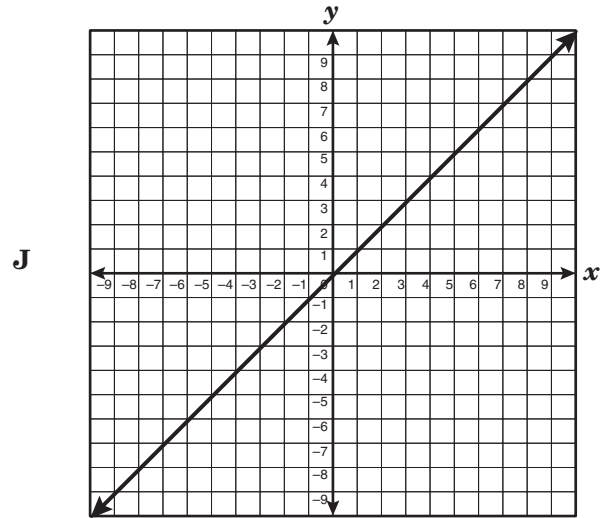
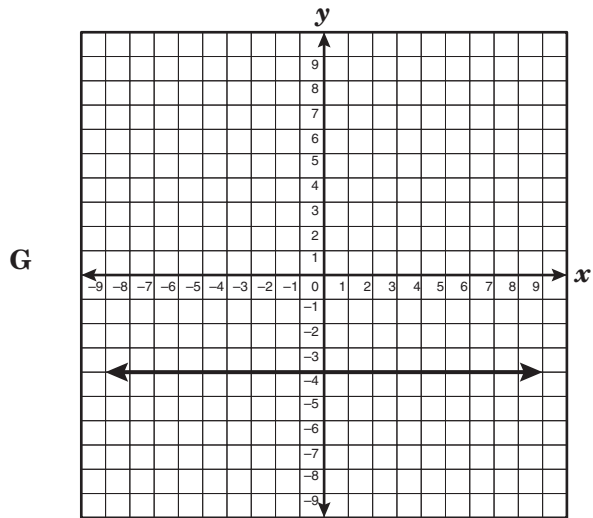
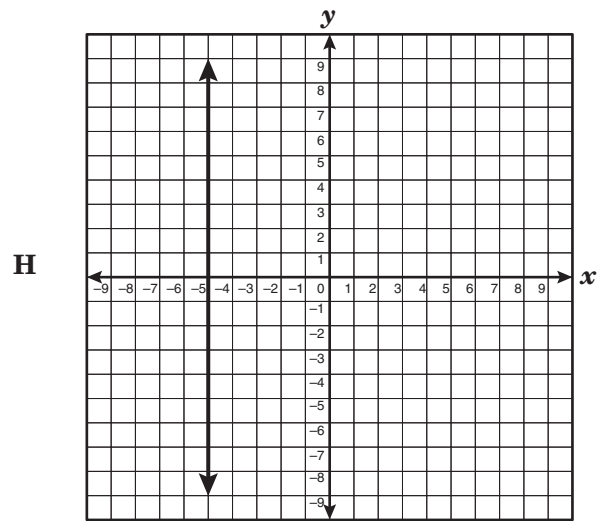
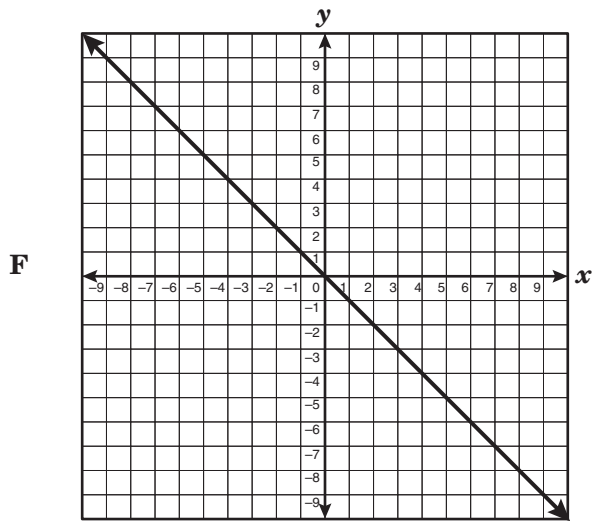



23 Look at the drawing shown below.

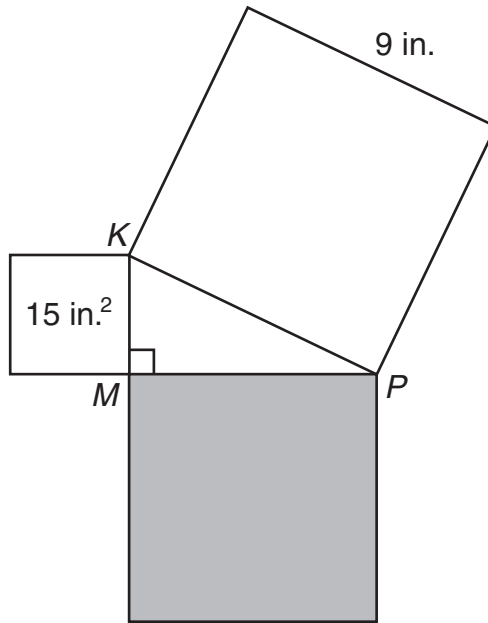

If  $\triangle KMP$  is a right triangle formed by the placement of 3 squares, what is the area of the shaded square?

- A  $135 \text{ in.}^2$
- B  $24 \text{ in.}^2$
- C  $66 \text{ in.}^2$
- D  $81 \text{ in.}^2$

**24** The integers 1881, 353, 2002, and 787 are palindrome integers. Which of the following is also a palindrome integer?

- F** 1961
- G** 828
- H** 2525
- J** 783

**25** In many parades, flowers are used to decorate the floats. The table below shows the number of flowers used in each row of a parade float.

Row Number, $r$	Number of Flowers, $n$
1	54
2	58
3	62
4	66

Which equation best describes these data?

- A**  $n = 2r + 52$
- B**  $n = r + 54$
- C**  $n = 4r + 50$
- D**  $n = 4r + 54$

**26** If the dimensions of a rectangle are doubled, which of the following best describes an effect on the rectangle?

- F** The new area will be 2 times as large as the original area.
- G** The new area will be 8 times as large as the original area.
- H** The new perimeter will be 4 times as large as the original perimeter.
- J** The new perimeter will be 2 times as large as the original perimeter.

**27** Harris has \$20.92 to spend on video-game rentals at a local video store. The store charges \$3.95 per video-game rental plus an 8.125% tax. What is the maximum number of video games that Harris can rent?

- A** 5
- B** 4
- C** 6
- D** 3

- 28 When Memorial Elementary held its annual spring festival, Benjamin surveyed 100 students to see which activity they preferred. The graph below shows the results of Benjamin's survey.

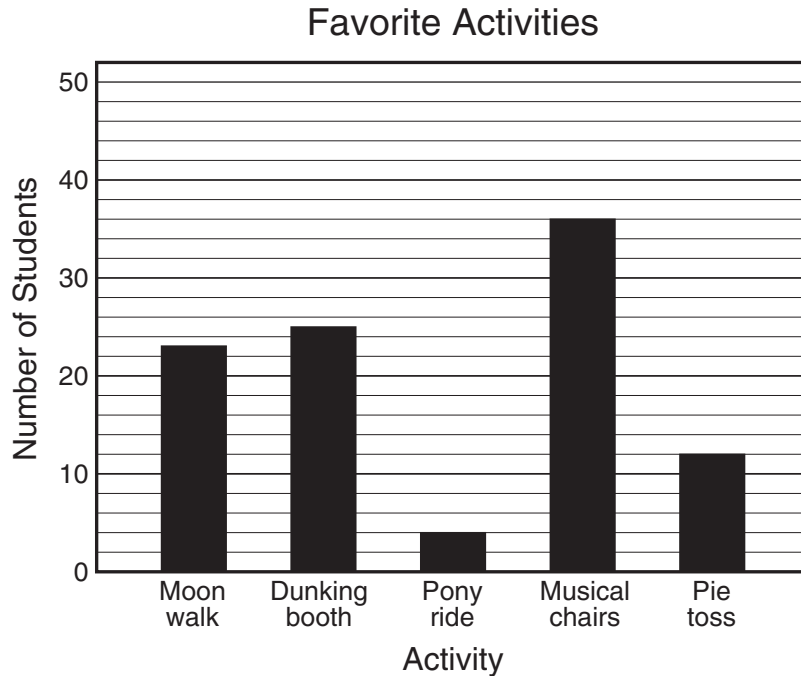

Which of the following statements is supported by these data?

- F Close to half the students surveyed preferred either the moon walk or the dunking booth.
- G More than 25% of the students surveyed preferred the pony ride or the pie toss.
- H The ratio of students who preferred musical chairs to the pie toss was 1:3.
- J More students preferred musical chairs than preferred all the other activities combined.

- 29 Ms. Díaz asked each of her 27 statistics students to write down an integer from 1 to 10. To determine the most common number the students picked, which measure of central tendency should Ms. Díaz use?

- A Mode
- B Mean
- C Median
- D Range

- 30 Mr. Ross is purchasing a table and chairs for \$1350, including tax and interest. He will pay for the furniture with monthly payments of \$75. If Mr. Ross has made  $m$  payments, which equation best describes  $r$ , the amount of the remaining balance?

- F  $r = (1350 - 75)m$
- G  $r = 75m + 1350$
- H  $r = 1350 - 75m$
- J  $r = 75m - 1350$

- 31 The student council members are making decorative labels to cover 20 identical empty coffee cans for a charity drive. Each label will cover the entire lateral surface area of a can.

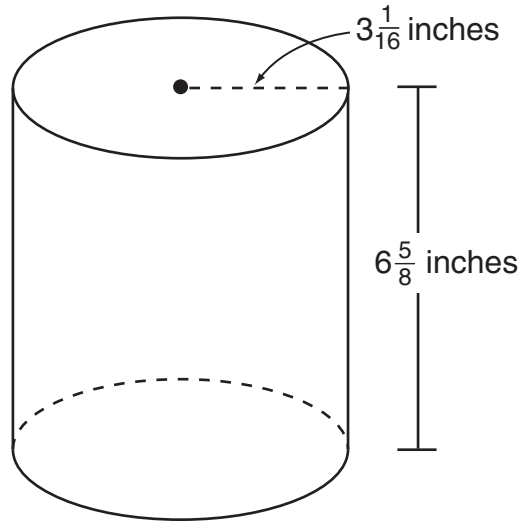

Which is closest to the lateral surface area of a single coffee can?

- A 186 in.<sup>2</sup>  
B 157 in.<sup>2</sup>  
C 195 in.<sup>2</sup>  
D 128 in.<sup>2</sup>
- 
- 32 The perimeter of a rectangular wooden deck is 90 feet. The deck's length,  $l$ , is 5 feet less than 4 times its width,  $w$ . Which system of linear equations can be used to determine the dimensions, in feet, of the wooden deck?
- F  $2l + 2w = 90$   
 $l = 5 - 4w$
- G  $2l + 2w = 90$   
 $l = 5w - 4$
- H  $2l + 2w = 90$   
 $l = 4 - 5w$
- J  $2l + 2w = 90$   
 $l = 4w - 5$

- 33 The graph below shows the relationship between the distance in miles a delivery truck traveled and the number of hours each delivery took.

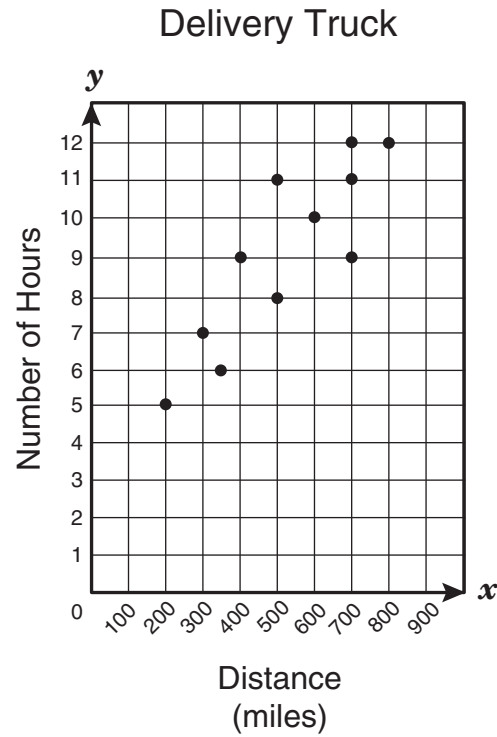

Which best describes the relationship shown on the graph?

- A Negative trend
- B Positive trend
- C Constant trend
- D No trend

- 34 Which expression represents the area of a rectangle with sides measuring  $2x^2y^4z$  units and  $5xy^4z^3$  units?
- F  $7x^2y^8z^3$  units<sup>2</sup>
- G  $7x^3y^8z^4$  units<sup>2</sup>
- H  $10x^3y^8z^4$  units<sup>2</sup>
- J  $10x^2y^8z^3$  units<sup>2</sup>

- 35 Mr. Carpenter built a wooden gate, as shown below.

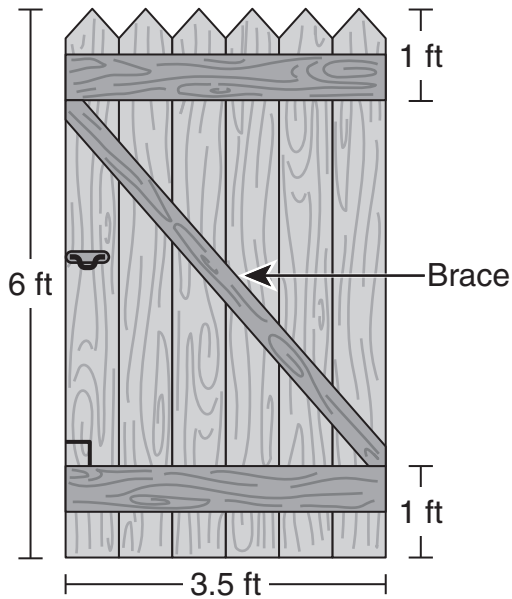

Which is closest to the length in feet of the diagonal board that Mr. Carpenter used to brace the wooden gate?

- A 4.9 ft
- B 5.3 ft
- C 6.1 ft
- D 6.9 ft

- 36 Heidi has a main-course choice of a hamburger, a hot dog, an egg roll, a taco, a fish sandwich, or a chicken sandwich. She has a side-order choice of french fries, corn chips, potato chips, or a salad. Heidi's beverage choice can be a soda, fruit punch, milk, or water. Which is the best method to determine how many different combinations Heidi could choose?

- F Add the total number of items in the 3 categories together
- G Multiply the total number of main-course choices by the total number of side-order choices and add the product to the total number of beverage choices
- H Multiply the sum of the total number of main-course choices and the total number of side-order choices by the total number of beverage choices
- J Multiply the total number of items in each of the 3 categories together

- 37 The graph below represents Lynne's car trip from her house to the mall and then back to her house.

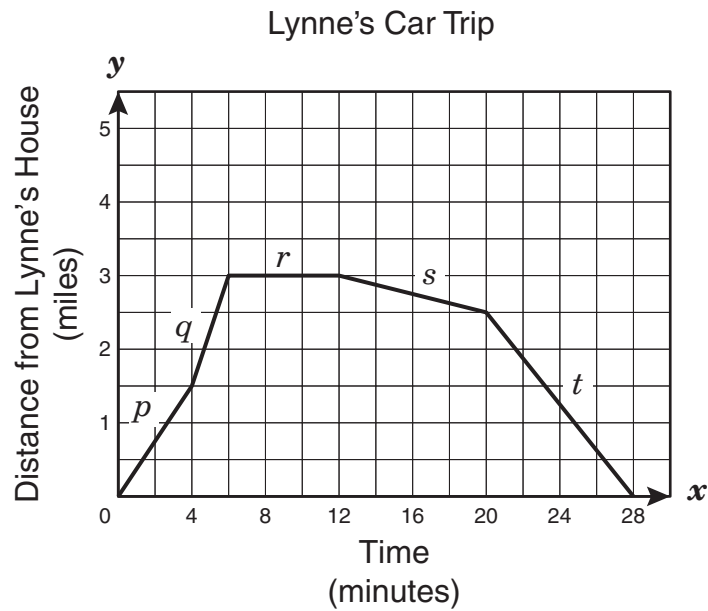

If each section of the graph represents part of Lynne's trip, which part of the trip took the least amount of time?

- A**  $r$
- B**  $p$
- C**  $q$
- D**  $s$
- 
- 38 Brandon has a budget of \$58 to spend on clothes. The shirts he wants to buy are on sale for \$9 each, and the pair of pants he wants costs \$21. All prices include tax. Which inequality could be used to determine  $s$ , the maximum number of shirts Brandon can buy if he also buys the pair of pants?
- F**  $21s + 9 < 58$
- G**  $9s + 21 \leq 58$
- H**  $30s < 58$
- J**  $9s - 21 \leq 58$

- 39 Which point on the grid below best represents the coordinates  $(\frac{8}{3}, \frac{7}{3})$ ?

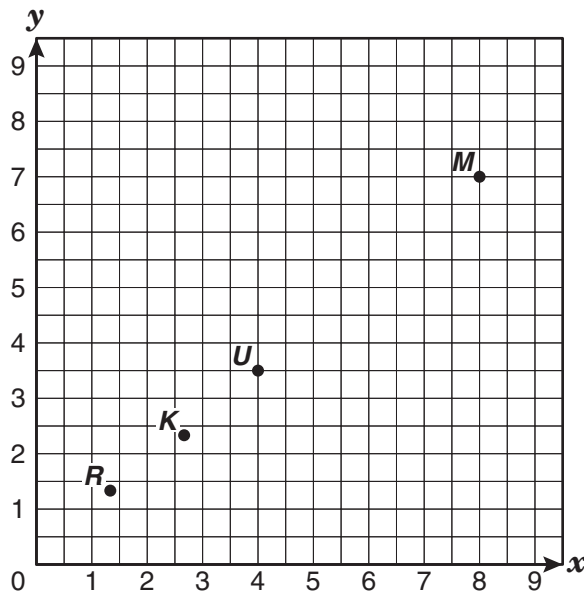

- A Point  $K$   
B Point  $M$   
C Point  $R$   
D Point  $U$
- 
- 40  $\triangle LMN$  has vertices  $L(a, b)$ ,  $M(r, s)$ , and  $N(u, v)$ . What will be the new coordinates of point  $M$  if the triangle is translated 7 units to the right and 3 units down?
- F  $(r + 3, s - 7)$   
G  $(r + 7, s - 3)$   
H  $(r - 7, s + 3)$   
J  $(r - 3, s + 7)$
- 41 To find  $c$ , the total cost of an order of DVDs from a certain website, the equation  $c = 19.99n + 4.99$  can be used, where  $n$  represents the number of DVDs ordered. If  $c$  is a function of  $n$ , which of the following best describes this relationship?
- A The value of  $n$  is constant in relation to  $c$ .  
B The value of  $n$  is dependent on  $c$ .  
C The value of  $c$  is constant in relation to  $n$ .  
D The value of  $c$  is dependent on  $n$ .



- 42 Mrs. Shawnee wants to buy fresh cherries to make some cherry pies for the school bake sale. The table below shows the sale prices of fresh cherries at 4 local markets.

Cherry Prices

Market	Cherries
Rosie's Fruit Stand	6 pints for \$5.40
Fruits and More	1 gallon for \$5.80
Nicky's Fruit Store	2 quarts for \$3.00
Freshly Picked Fruits	11 cups for \$4.50

According to the table, which market has the best sale price per cup of cherries?

- F Rosie's Fruit Stand
- G Fruits and More
- H Nicky's Fruit Store
- J Freshly Picked Fruits

- 
- 43 Narong's family bought 3 shirts, 2 pairs of jeans, and 2 pairs of shoes. Each shirt cost \$18, and each pair of shoes cost \$35. The jeans were marked down from their original price of \$40. What other information, if any, is needed to find the total cost of the 7 items before tax?

- A The percent markdown for the shirts
- B The original price of the jeans
- C The percent markdown for the jeans
- D No additional information is needed.

44  $\triangle MNQ$  is similar to  $\triangle MLP$ .

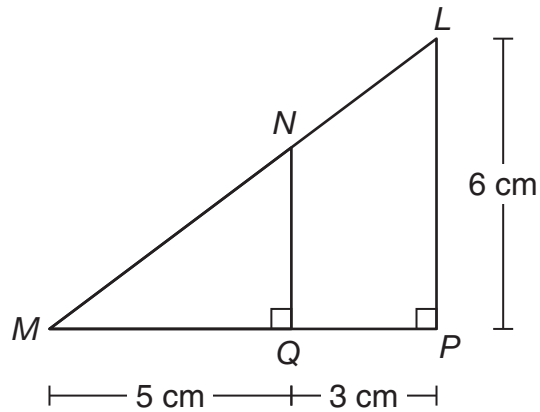

If  $ML = 10$  centimeters, what is the length of  $\overline{MN}$ ?

- F 6.25 cm
- G 8.3 cm
- H 7.5 cm
- J 4 cm

45 A jar contains 6 red marbles and 10 blue marbles, all of equal size. If Dominic were to randomly select 1 marble without replacement and then select another marble from the jar, what would be the probability of selecting 2 red marbles from the jar?

- A  $\frac{9}{64}$
- B  $\frac{1}{8}$
- C  $\frac{3}{5}$
- D  $\frac{3}{8}$

- 46 The graph of the function  $y = x^2 - 3$  is shown below.

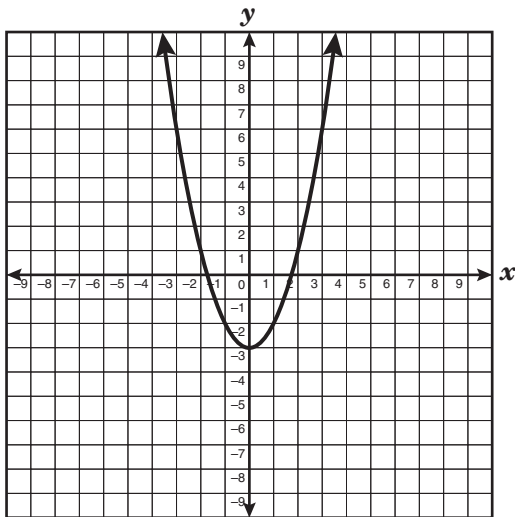

If the graph of the original function is shifted 5 units up, which of the following equations best represents the translation of each point on the curve?

- F  $y = x^2 + 5$
- G  $y = x^2 + 2$
- H  $y = x^2 - 2$
- J  $y = x^2 - 8$

- 47 What is the simplified form of  $\frac{a^4 b^2 c}{a^3 b^5 c^2}$ ?

A  $ab^3c^2$

B  $\frac{a}{b^3c^3}$

C  $a^7b^7c^3$

D  $\frac{a}{b^3c}$

48 The drawing below shows a solid with hexagonal bases.

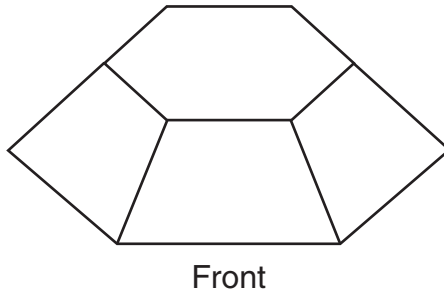

Which drawing best represents the top view of this hexagonal solid?

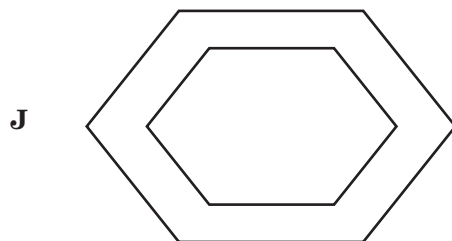
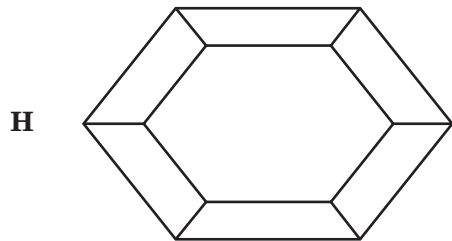
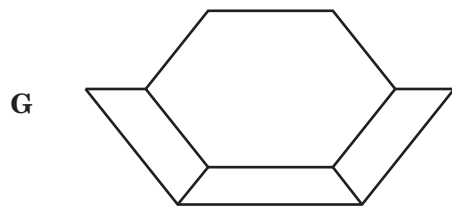
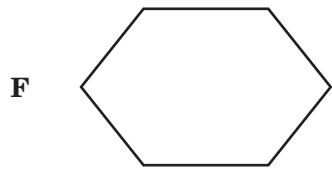

- 49 Line  $t$  intersects parallel lines  $l_1$  and  $l_2$ , as shown below.

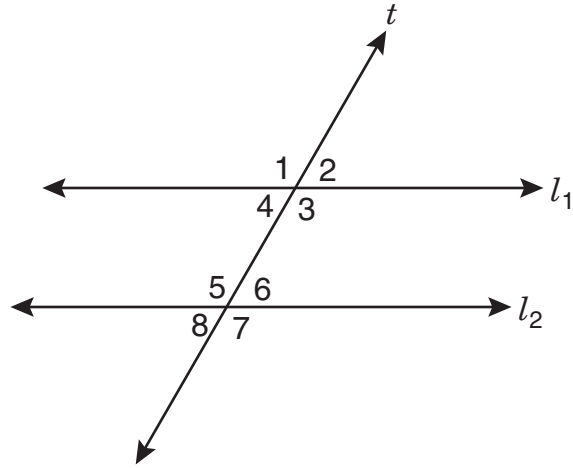

According to the information provided, which of the following pairs of angles are not always congruent?

- A Same-side interior angles 4 and 5
- B Alternate interior angles 3 and 5
- C Corresponding angles 2 and 6
- D Vertical angles 5 and 7

50 The table below shows the number of student absences for the school year in Mr. Cruz's math classes.

Student Absences

Days Absent	Number of Students
0	73
1	55
2	6
3	3
More than 3	6

Which of the following graphs best represents the data shown in the table?

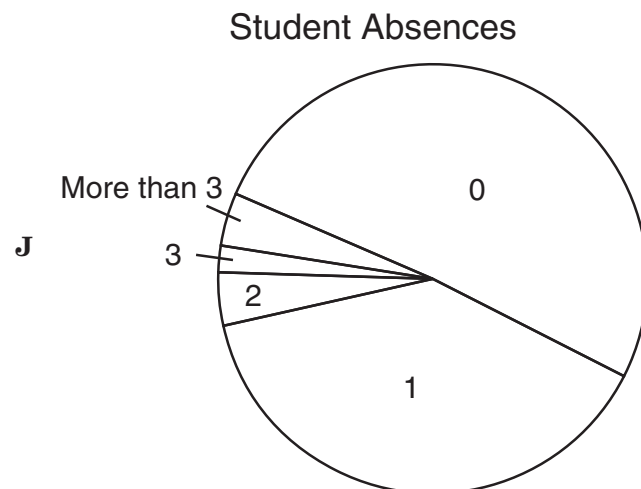
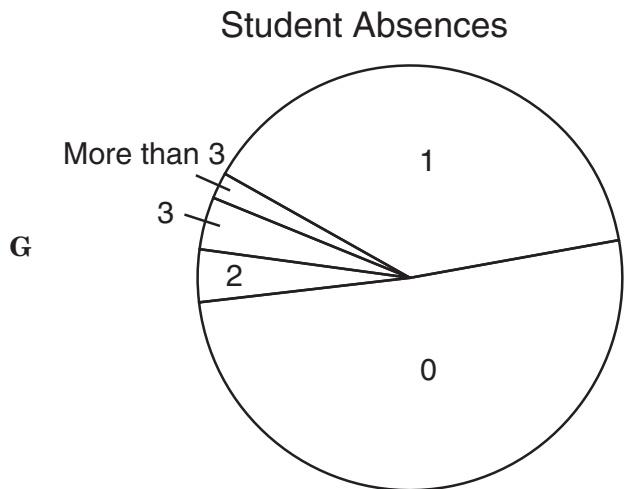
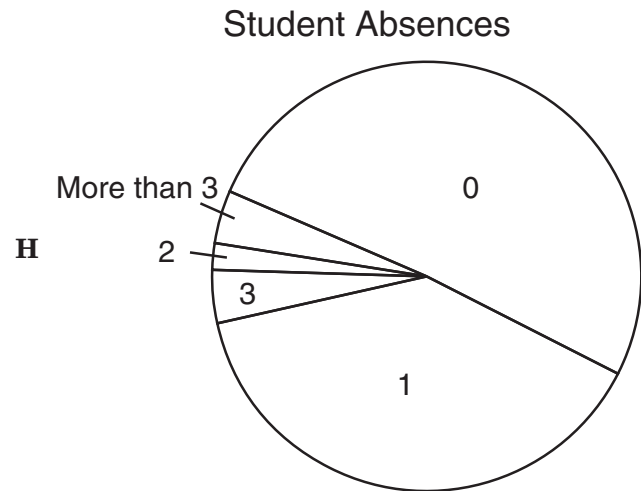
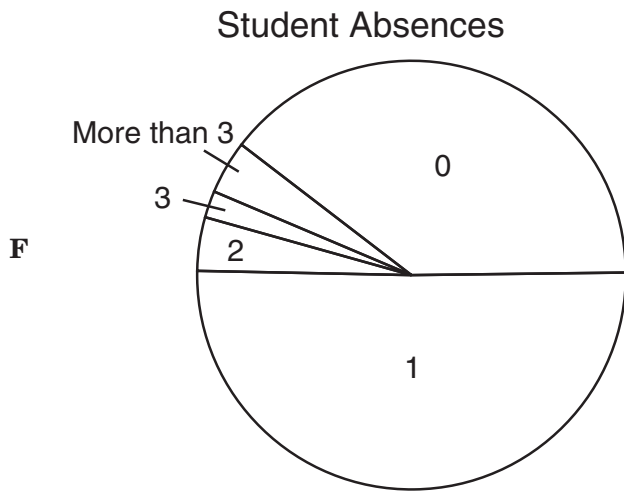

51 Look at the graph below.

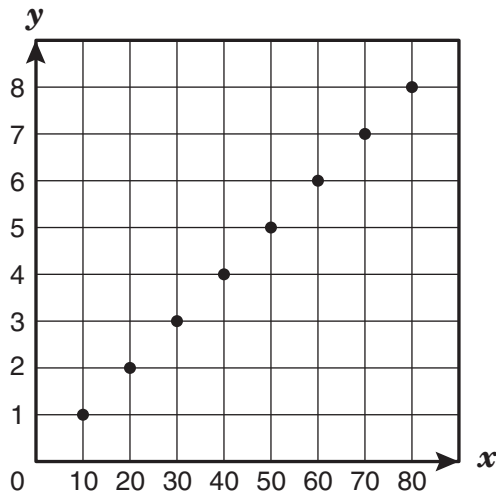

Which is the best interpretation of this graph?

- A Jorge earns \$20 for each hour worked.
- B For every 10 pieces of candy Stacey buys, she pays \$1.
- C For every 10 students at a dance, 2 teachers are needed as chaperones.
- D A runner runs at a constant rate of 2 miles every 30 minutes.

52 A florist plans to sell bouquets for \$25 each. He wants to use only roses and carnations in each bouquet and needs to charge the following amount for each type of flower.

\$1.50 per rose

\$1.25 per carnation

Which of these combinations of roses and carnations will result in bouquets that the florist can sell for exactly \$25 each?

- I. 18 roses and 2 carnations
- II. 6 roses and 10 carnations
- III. 10 roses and 8 carnations
- IV. 5 roses and 14 carnations

- F I and II only
- G II and III only
- H III and IV only
- J I and IV only

BE SURE YOU HAVE RECORDED ALL OF YOUR ANSWERS  
ON THE ANSWER DOCUMENT.







